



Bagger

Ice Bagger

Features:

- Improves profits
- Bag-N-Sell extra ice
- Time saving
- Less melting
- Innovative design
- Self standing
- Slips over bin front for easy access
- Plastic handle ice bag wicket





Bagger

Technical Specifications:

Width: 13" (33 cm)

Depth: 11" (28 cm)

Height: 30" (76 cm)

Agency Listings:

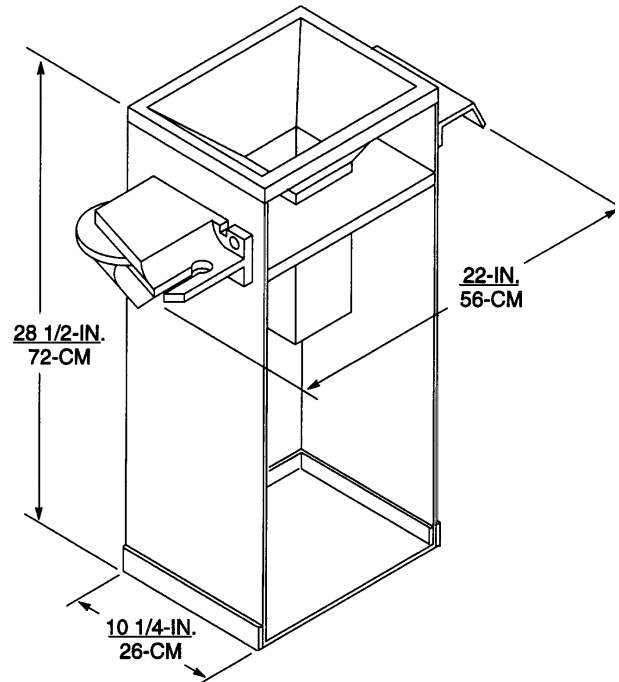

Part No./	Description	Shipping Weight
B28	Bagger Kit with sealing tape dispenser	15 lbs./6.8 kgs.
BG8	Bags, 1000 count 8 lb. ice bags	28 lbs./12.7 kgs.
TR2	Tape, (single roll)	1/2 lbs./23 kgs.



For more information or to place an order, contact your sales representative or authorized distributor.

In the US:

Phone: 1-800-238-3600

Fax: 1-800-535-4235

Outside the US:

Phone: 1-612-421-6120

Fax: 1-612-422-3297

IMI Cornelius Inc.

One Cornelius Place
Anoka, MN 55303-6234
USA